

OM SENI

SM8S10(C)A thru SM8S43(C)A

Stand-off Voltage - 10 to 43 Volts

Surface Mount Transient Voltage Suppressors

High Temperature Stability and High Reliability Conditions



Features

- Round chip produced by chemical method
- Junction passivated by polyimide
- $T_J = 175\text{ }^\circ\text{C}$ capability suitable for high reliability and automotive requirement
- Available in uni-directional and bi-directional polarity
- Low leakage current
- Low forward voltage drop
- High surge capability
- Meets MSL level 1, per J-STD-020, LF maximum peak of $245\text{ }^\circ\text{C}$



DO-218AB



Unipolar

Bipolar

MECHANICAL DATA

Case: DO-218AB

Terminals: matte tin plated leads, solderable per J-STD-002 and JESD 22-B102

Polarity: heatsink is anode

Package: DO-218AB

TYPICAL APPLICATIONS

Use in sensitive electronics protection against voltage transients induced by inductive load switching and lighting, especially for automotive load dump protection application.

Maximum Ratings and Electrical characteristics

Ratings at $25\text{ }^\circ\text{C}$ ambient temperature unless otherwise specified.

Parameter	Symbol	Value	Unit
Peak pulse power dissipation with 10/1000 μs waveform with 10/10 000 μs waveform	P_{PPM}	6600	W
		5200	
Power dissipation on infinite heatsink at $T_C = 25\text{ }^\circ\text{C}$ (fig. 1)	P_D	8.0	W
Peak pulse current with 10/1000 μs waveform	$I_{PPM}^{(1)}$	See next table	A
Peak forward surge current 8.3 ms single half sine-wave	I_{FSM}	700	A
Typical thermal resistance, junction to case	$R_{\theta JC}$	0.90	$^\circ\text{C/W}$
Operating junction and storage temperature range	T_J, T_{STG}	-55 to +175	$^\circ\text{C}$

Note

⁽¹⁾ Non-repetitive current pulse derated above $T_A = 25\text{ }^\circ\text{C}$

OM SENI

ELECTRICAL CHARACTERISTICS ($T_C = 25\text{ }^\circ\text{C}$ unless otherwise noted)

DEVICE TYPE		BREAKDOWN VOLTAGE V_{BR} (V)			TEST CURRENT I_T (mA)	STAND-OFF VOLTAGE V_{WM} (V)	MAXIMUM REVERSE LEAKAGE AT V_{WM} I_D (μA)	MAXIMUM REVERSE LEAKAGE AT V_{WM} $T_J = 175\text{ }^\circ\text{C}$ I_D (μA)	MAX. PEAK PULSE CURRENT AT 10/1000 μs WAVEFORM (A)	MAXIMUM CLAMPING VOLTAGE AT 1PPM V_C (V)	TYPICAL TEMP. COEFFICIENT OF V_{BR} ⁽¹⁾ α_T ($\%/^\circ\text{C}$)
Uni.	Bi.	MIN.	NOM.	MAX.							
SM8S10A	SM8S10CA	11.1	11.7	12.3	5.0	10.0	15	250	388	17.0	0.069
SM8S11A	SM8S11CA	12.2	12.9	13.5	5.0	11.0	10	150	363	18.2	0.072
SM8S12A	SM8S12CA	13.3	14.0	14.7	5.0	12.0	10	150	332	19.9	0.074
SM8S13A	SM8S13CA	14.4	15.2	15.9	5.0	13.0	10	150	307	21.5	0.076
SM8S14A	SM8S14CA	15.6	16.4	17.2	5.0	14.0	10	150	284	23.2	0.078
SM8S15A	SM8S15CA	16.7	17.6	18.5	5.0	15.0	10	150	270	24.4	0.080
SM8S16A	SM8S16CA	17.8	18.8	19.7	5.0	16.0	10	150	254	26.0	0.081
SM8S17A	SM8S17CA	18.9	19.9	20.9	5.0	17.0	10	150	239	27.6	0.082
SM8S18A	SM8S18CA	20.0	21.1	22.1	5.0	18.0	10	150	226	29.2	0.083
SM8S20A	SM8S20CA	22.2	23.4	24.5	5.0	20.0	10	150	204	32.4	0.085
SM8S22A	SM8S22CA	24.4	25.7	26.9	5.0	22.0	10	150	186	35.5	0.086
SM8S24A	SM8S24CA	26.7	28.1	29.5	5.0	24.0	10	150	170	38.9	0.087
SM8S26A	SM8S26CA	28.9	30.4	31.9	5.0	26.0	10	150	157	42.1	0.088
SM8S28A	SM8S28CA	31.1	32.8	34.4	5.0	28.0	10	150	145	45.4	0.089
SM8S30A	SM8S30CA	33.3	35.1	36.8	5.0	30.0	10	150	136	48.4	0.090
SM8S33A	SM8S33CA	36.7	38.7	40.6	5.0	33.0	10	150	124	53.3	0.091
SM8S36A	SM8S36CA	40.0	42.1	44.2	5.0	36.0	10	150	114	58.1	0.091
SM8S40A	SM8S40CA	44.4	46.8	49.1	5.0	40.0	10	150	102	64.5	0.092
SM8S43A	SM8S43CA	47.8	50.3	52.8	5.0	43.0	10	150	95.1	69.4	0.093

Notes

- For all types maximum $V_F = 1.8\text{ V}$ at $I_F = 100\text{ A}$ measured on 8.3 ms single half sine-wave or equivalent square wave, duty cycle = 4 pulses per minute maximum

(1) To calculate V_{BR} vs. junction temperature, use the following formula: V_{BR} at $T_J = V_{BR}$ at $25\text{ }^\circ\text{C} \times (1 + \alpha_T \times (T_J - 25))$

OM SENI

RATINGS AND CHARACTERISTICS CURVES ($T_A = 25\text{ }^\circ\text{C}$ unless otherwise noted)

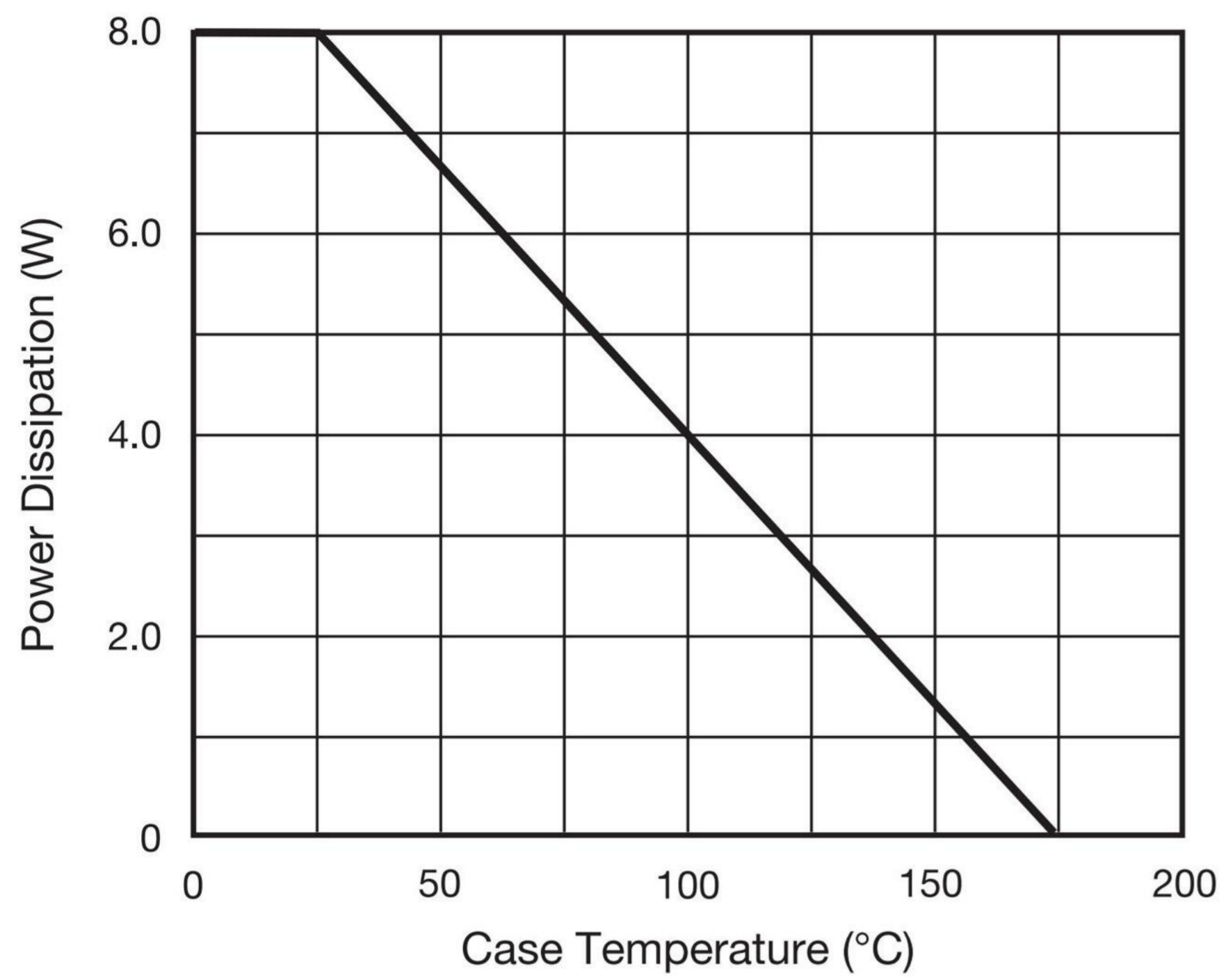

Fig. 1 - Power Derating Curve

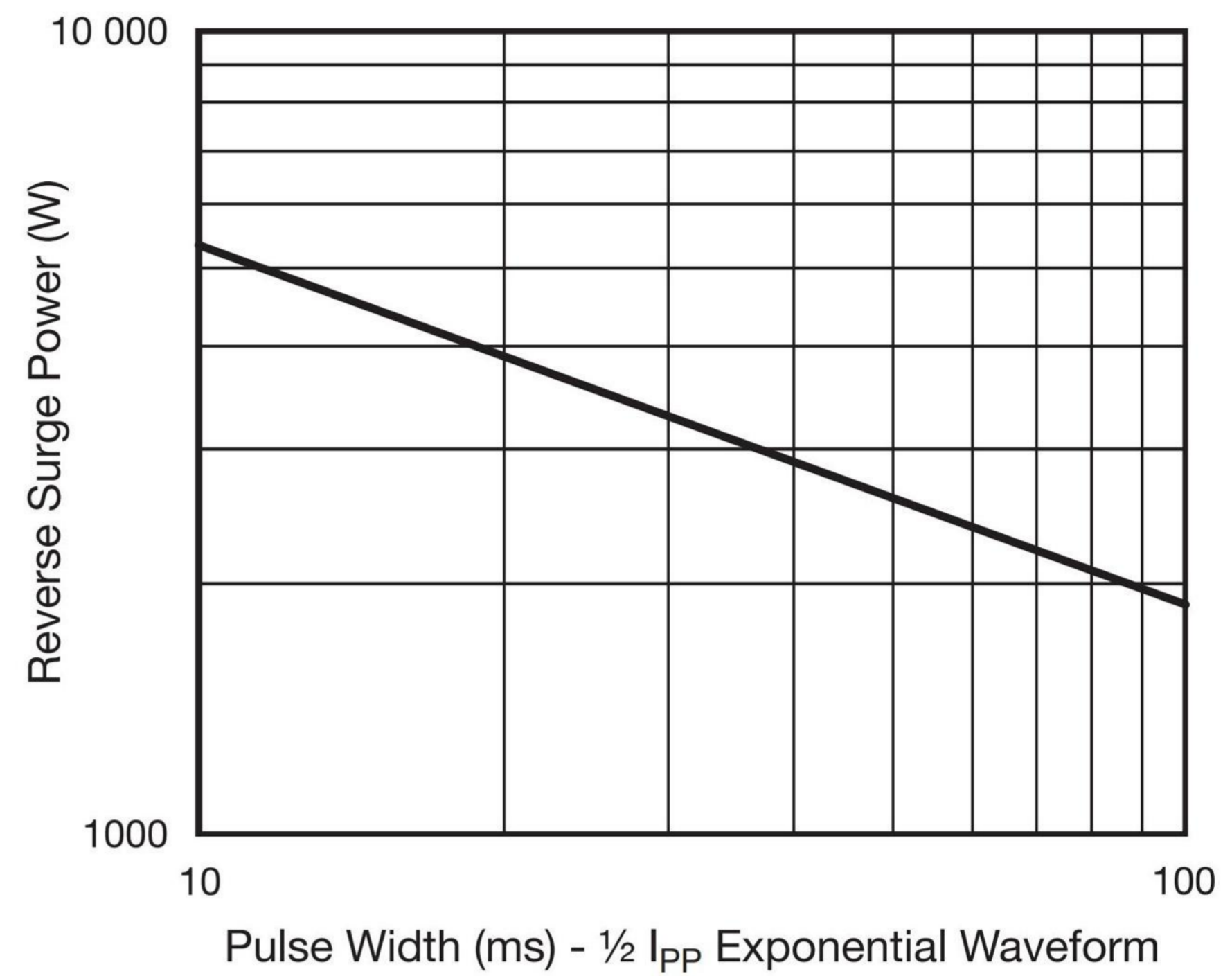

Fig. 4 - Reverse Power Capability

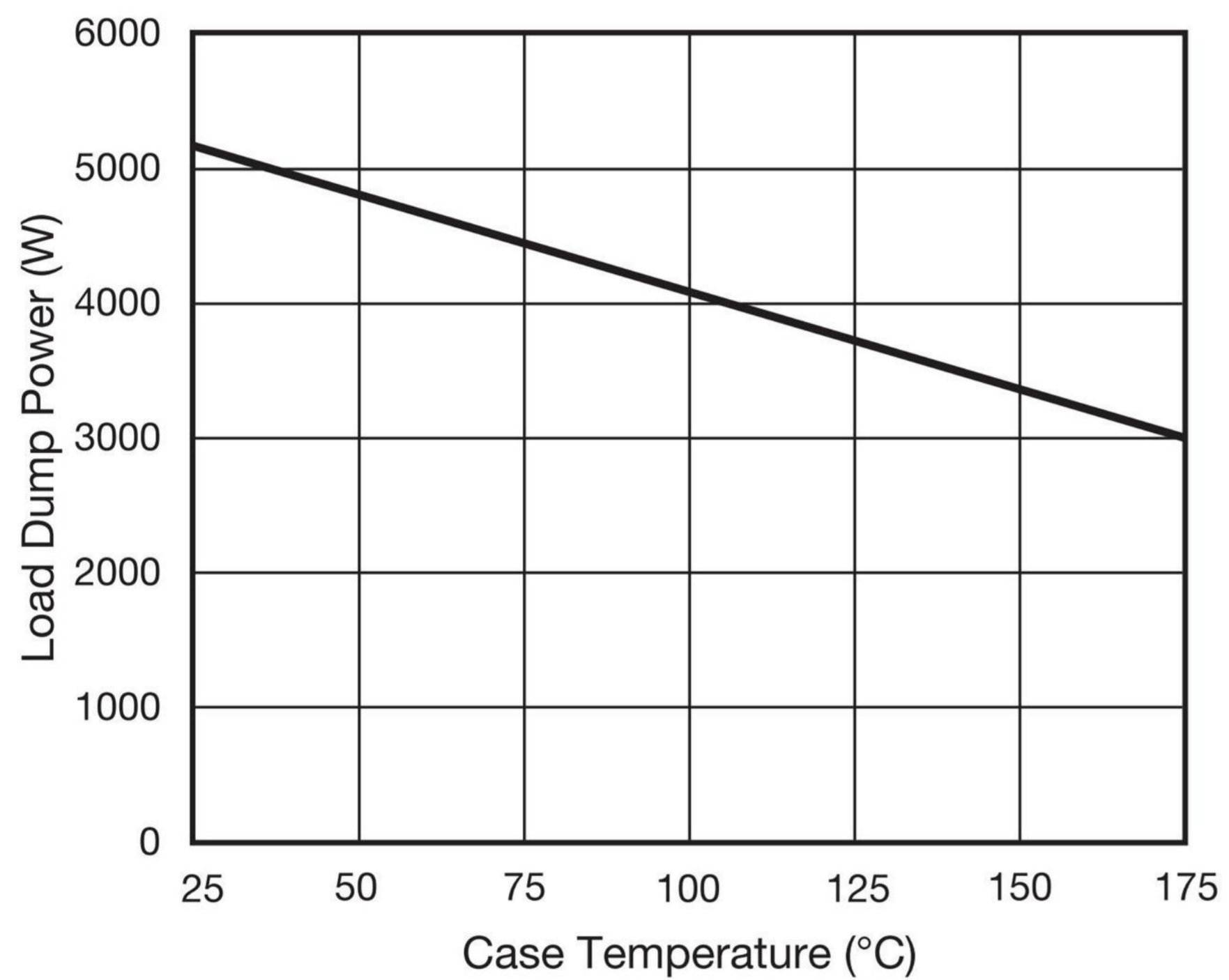

Fig. 2 - Load Dump Power Characteristics (10 ms Exponential Waveform)

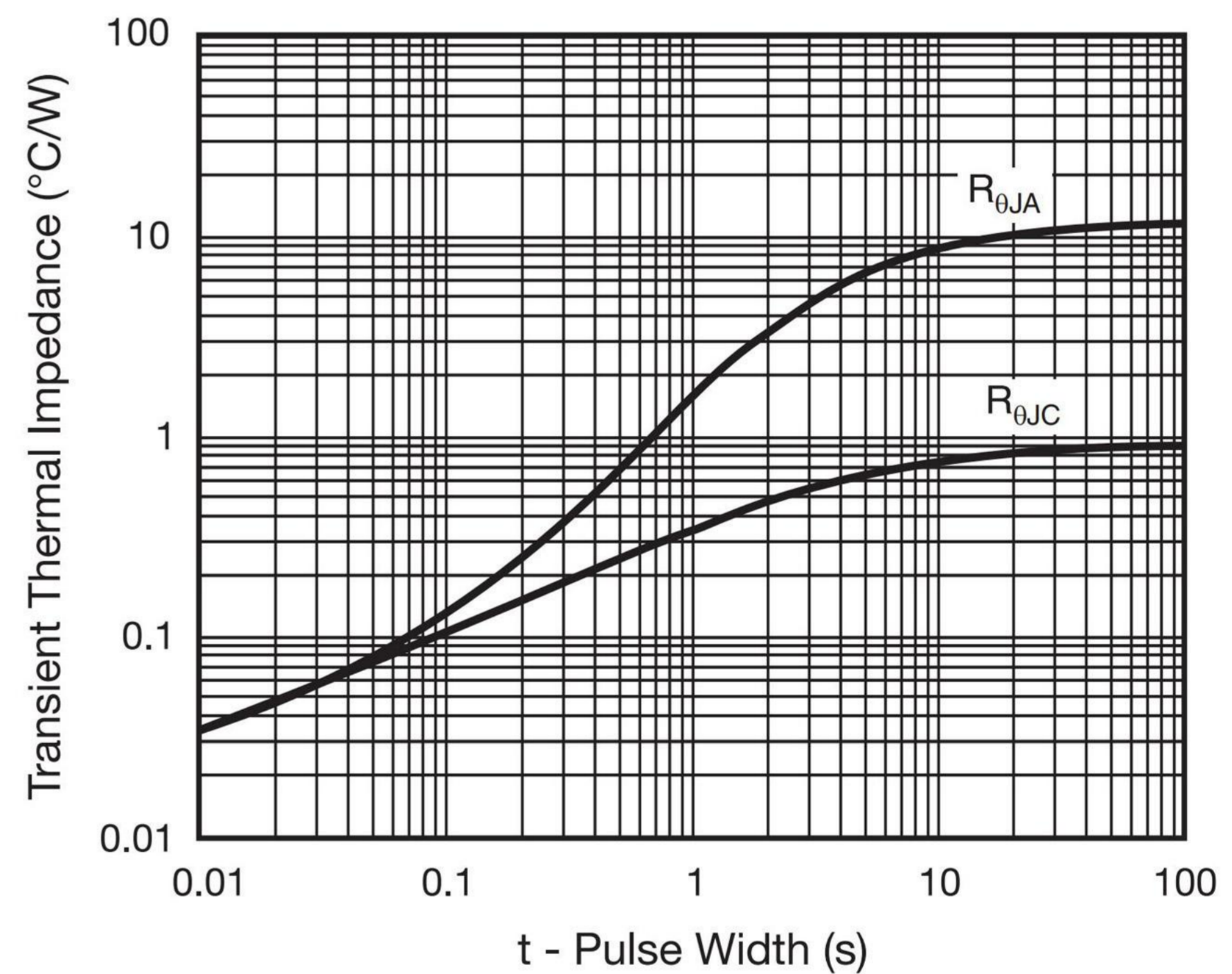

Fig. 5 - Typical Transient Thermal Impedance

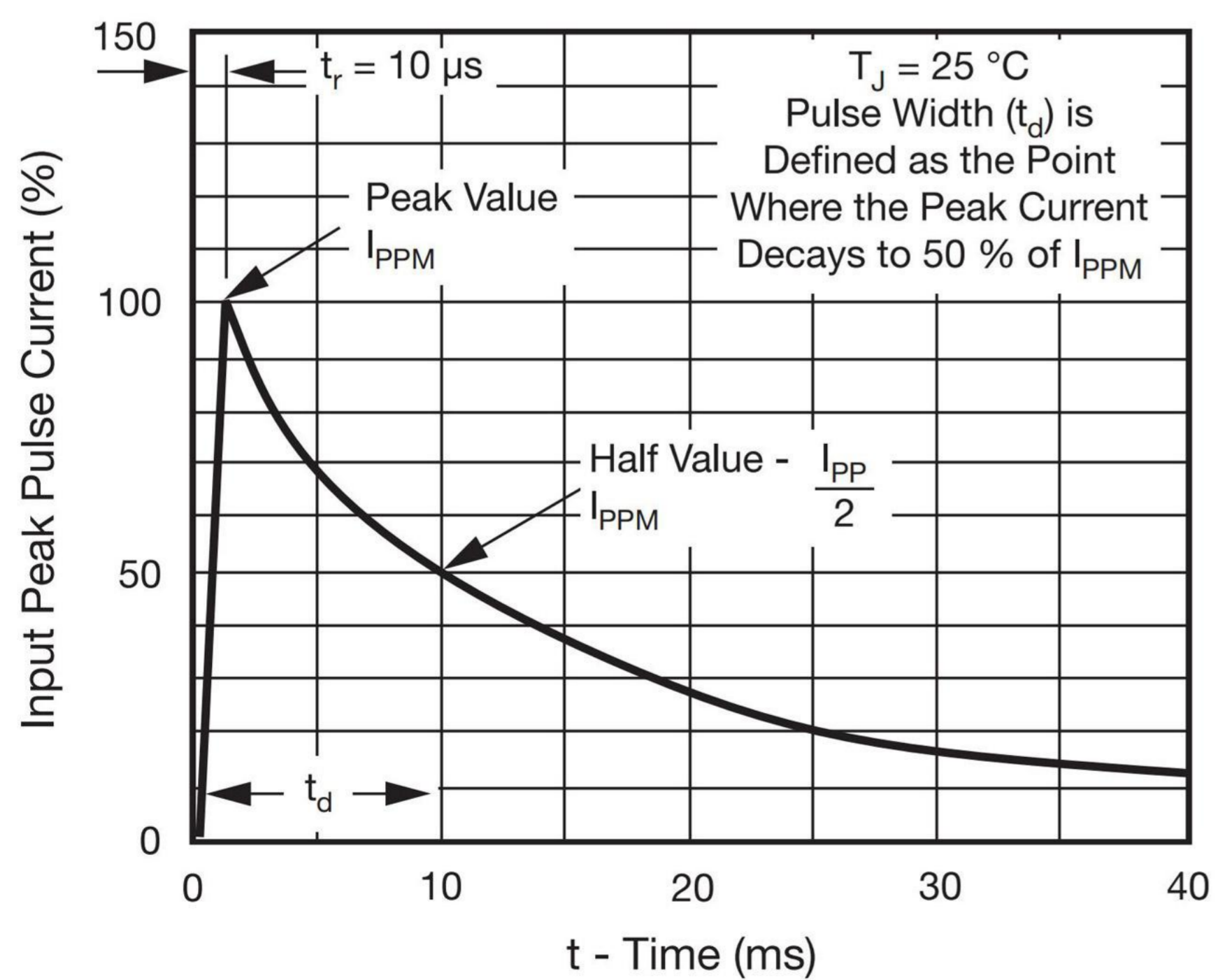

Fig. 3 - Pulse Waveform

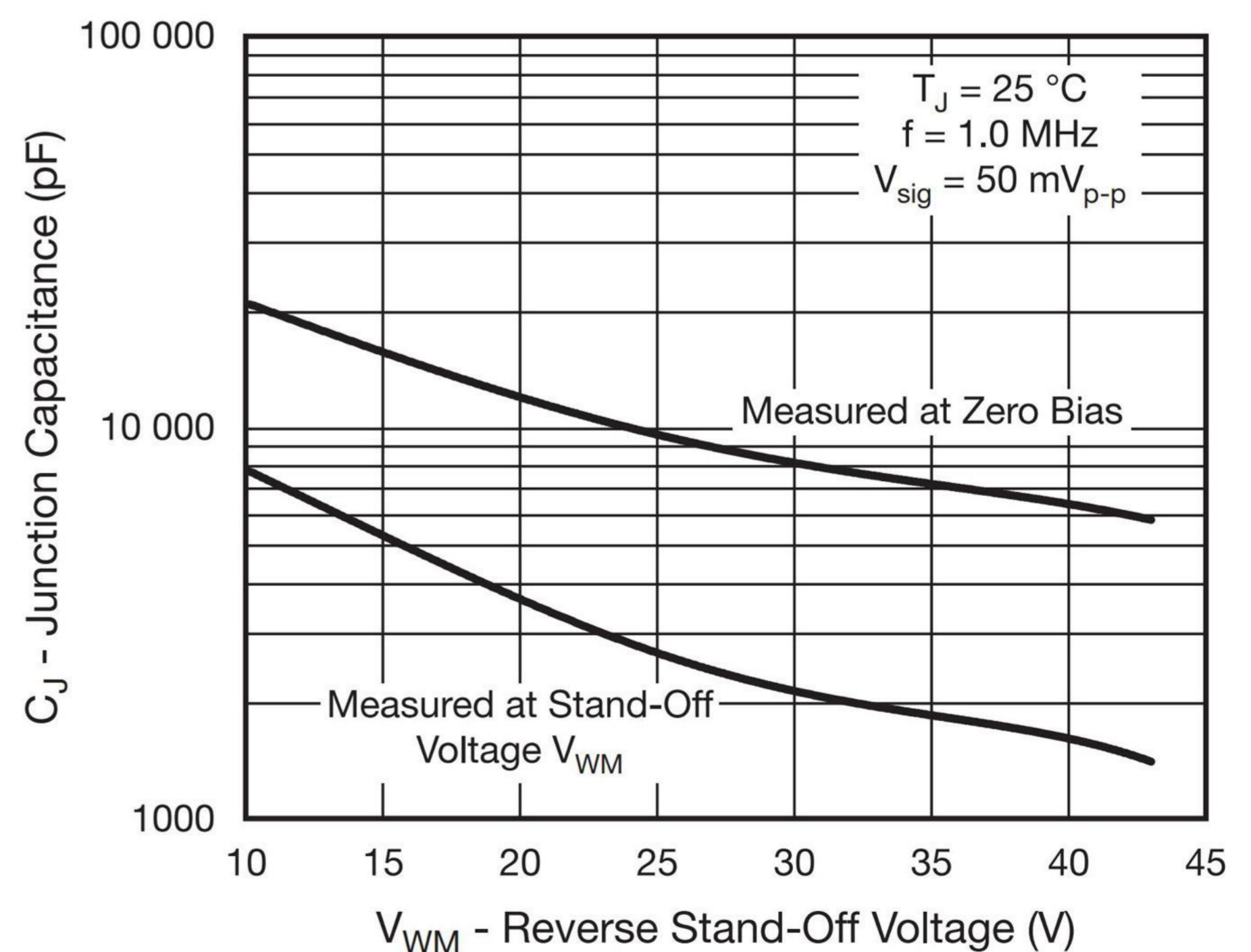
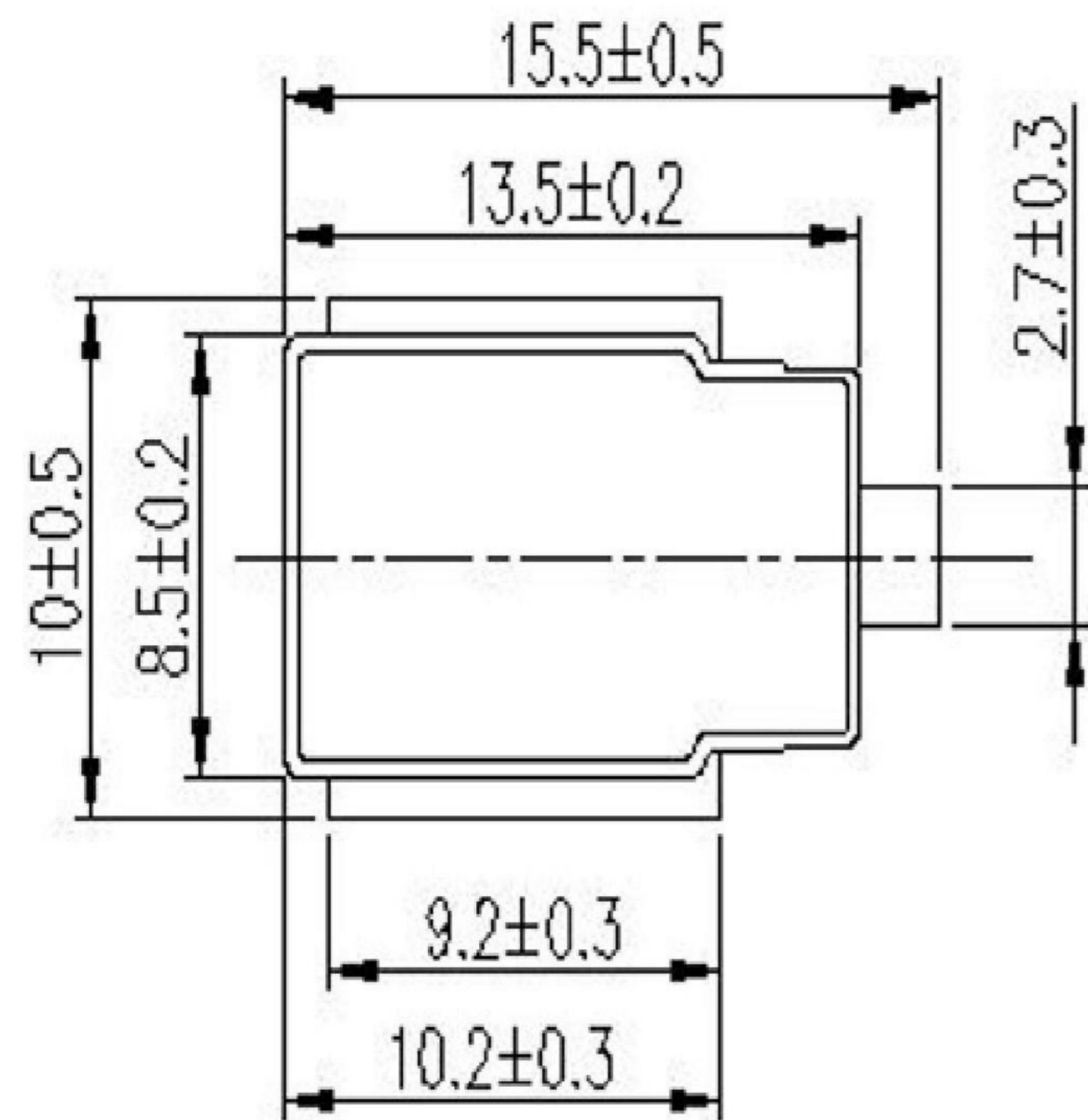

Fig. 6 - Typical Junction Capacitance

OM SENI

PACKAGE OUTLINE DIMENSIONS (millimeters)

DO-218AB



Mounting Pad Layout

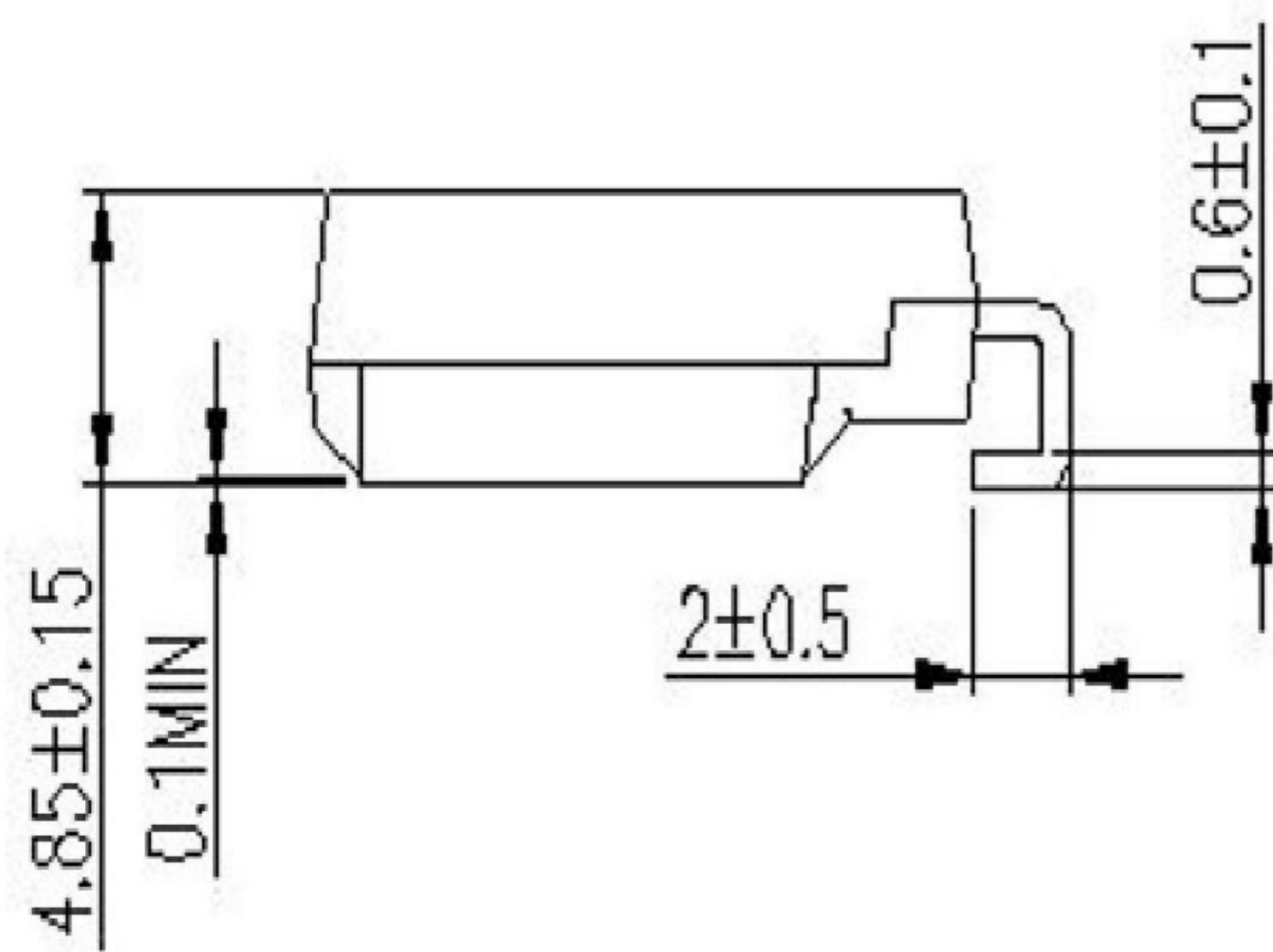
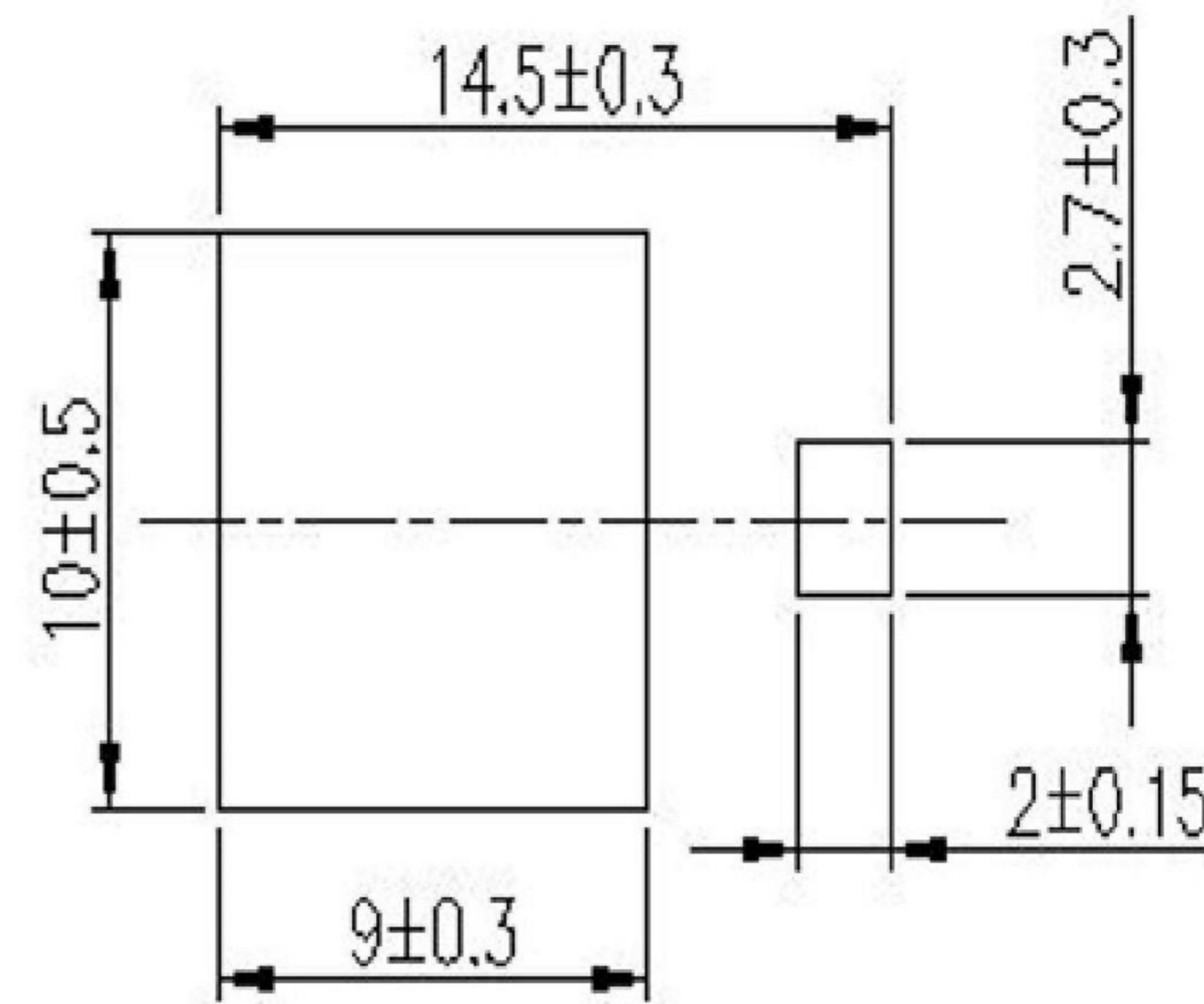

ORDERING INFORMATION (Example)

PREFERRED P/N	UNIT WEIGHT (g)	PACKAGE	BASE QUANTITY	DELIVERY MODE
SM8S	2.600	DO-218	NA	According to customer's requirement